

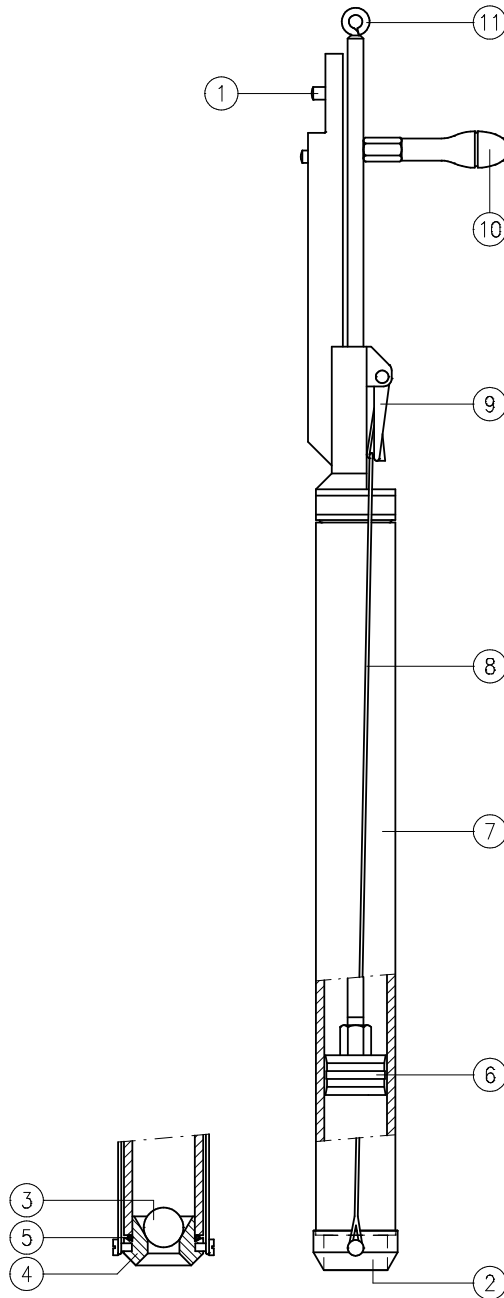

# Multisampler

## Manual



**Meet the difference**

## Contents

On these operating instructions .....	3
1. Short description .....	3
2. Introduction and decontamination .....	4
3. Application .....	5
3.1 Taking sludge- and sediment samples .....	5
3.2 Accessing sludge- and sediment samples .....	5
3.3 Taking liquid samples .....	6

Nothing in this publication may be reproduced and/or made public by means of print, photocopy, microfilm or any other means without previous written permission from Royal Eijkelkamp. Technical data can be amended without prior notification.  
Royal Eijkelkamp is not responsible for (personal damage due to (improper) use of the product.  
Royal Eijkelkamp is interested in your reactions and remarks about its products and operating instructions.

## On these operating instructions



**When the symbol shown on the left is placed before a piece of text, this means that an important instruction follows.**

### 1. Short description

The Multisampler has been developed to take samples from layered strata of sludge and sediment as well as from layered liquids.

The stratification of the sample taken remains reasonably intact. In liquids column- as well as point samples can be taken. The apparatus can be deployed up to a depth of several meters by applying extension rods with bayonet connection (1).

The standard model of the Multisampler is supplied with two cutting heads.

One open sharp cutting head (2) for taking column samples in more or less tough material “without” agitation, and a cutting head with ball valve seating (4) and ball (3) to be able to take semi-agitated samples from fluid material. The large passage of the ball valve enables sampling of extremely viscous- and/or heterogeneous material.

The length of the sample taken has a maximum of 1 meter, with a diameter of 40 mm. The volume of the sample is more than 1 liter. Because the sampling tube (7) is transparent, the contents can be judged visually immediately after raising. It is possible to transport the sample in the sampling tube for closer examination in a laboratory. This all makes that the Multisampler has a wide range of applications.

To avoid compaction of the sludge layers by the increasing resistance of the sample sliding into the sampling tube, a piston (6) with a piston rod with tread-eye (11) is kept at a stationary level in relation to the material to be sampled. The apparatus can only function properly if the sludge remains under a level of liquid or if the material itself is non-air permeable e.g. greases and pastes.

For the sampling of drained sediment the peat profile sampler (art. no.: 0409) or the flap gouge auger (art. no.: 2007) can be applied.

The metal parts of the Multisampler have been made of stainless steel. The sampling tube is made of PMMA acrylic high transparent plastic. A NBR-rubber piston (6) is applied. Under the condition that all precautions (cleaning, controlling) have been taken, the samples taken can be examined for all kinds of pollution.

For taking layered samples from unknown chemicals we refer to the rod- or cable operated liquid layer samplers (art. no.: 1240 and 1241). These have been fitted with a chemically inert PTFE sampling tube.

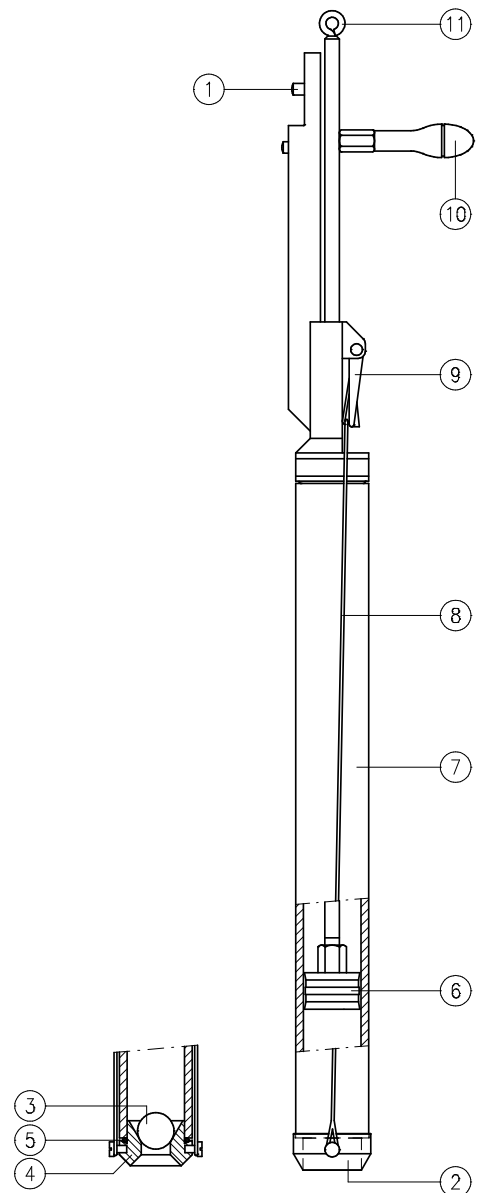

## 2. Introduction and decontamination

Every Multisampler leaving our plant is subjected to a final quality inspection. If nevertheless you would find any imperfections in the apparatus, then we request you to contact us.

On reception you should check whether all required and ordered parts are present and whether they are undamaged. The minimum you need would be:

1. The Multisampler (124201B) with two cutting heads (one of which has been mounted).
2. A handle to be able to operate the Multisampler (011001B or 011004B).
3. Possible one or more extension rods (011007B).
4. A cord to operate the piston rod (01090002).

Of course it is always possible to optionally add the following equipment:

5. Extra sampling tubes (124202) with extra pistons (124209).
6. Cap, polyethylene (124208).
7. Stainless steel ball (124206).
8. Decontamination fluid (art. no. 200529).
9. Stainless steel bucket (art. no. 990810).
10. Carrying bag (art. no. 0114).



**Only introduce the Multisampler after you read this manual.  
Keep this manual in a place accessible to all users.**



**Decontaminate the equipment before use.  
This avoids disappointment on reception of the first results!**



**For a complete decontamination (organic as well as anorganic) we recommend the application of phosphate-free Deconex (200529). The action of the detergents is increased substantially by using warm or even hot water. Always rinse with large quantities of clean water afterwards.**



**In combination with tissues, isopropyl alcohol can be used to quickly clean the apparatus in the field.**



**Volatile substances that entered the plastic through permeation will disappear from the apparatus by placing it in a ventilated warm place after carefully cleaning inside- and outside. In extreme cases the sampling tube can not be used again.**

Note: In the event of affect (by certain chemicals) of the PMMA or corrosion of the stainless steel, iron, nickel and chrome (from the stainless steel) and tin (from the PMMA) may be released. In such an event this should be taken into account on interpreting the results of the analysis.

### 3. Application

#### 3.1 Taking sludge- and sediment samples

Principle of operation:

The apparatus is pushed into the sludge. To avoid compaction of the layers a piston is held at a stationary position relative to the sludge.

Working procedure:

Assemble the Multisampler, fitted with the open cutting head (2) with centring pens (5) to avoid slipping off). See to it that the wires (8) that are holding the cutting ring are not pulled too tight. The adjustable hook (9) that pulls the wires can be unscrewed or screwed in. Mount no more than two extension rods and the handle and fit the piston rod (11) with a cord (you could use a plasticized cord).

Lower the apparatus until any resistance is felt (in case of application at greater depths additional extension rods are mounted during the lowering of the apparatus).

After feeling the sludge to be cut, the apparatus is lifted several decimeters.

Then the piston is blocked at a stationary level, for instance by pulling the cord tight and by standing on it.

Next the sampler is pushed into the sludge until it is filled-up completely or until too much resistance is felt (in case of the application of several extension rods it is important to cut fast and with short brisk movements to avoid bending).

After this the apparatus is pulled-up by the piston cord. Through an air valve in the top section of the Multisampler, air can leave, but not enter, the space over the piston which causes the piston to remain in place and the sample is kept inside by the slight underpressure.

#### 3.2 Accessing sludge- and sediment samples

- Rinse the outside of the sampler with water.
- Disconnect all rods (you may disconnect the piston cord).

Mind the following:

- Often several centimeters of 'air' can be seen under the piston. This gas stems from anaerobic decomposition of biologically active sludge. The vibrations occurring during the cutting cause the gas to bubble up and to collect under the piston. In such a case, gas bubbles will also be present in various places inside the sample, as can be seen as the tube is transparent.
  - Often vertical lines can be seen in addition to the horizontal lines caused by the different sediment layers in the sample. These lines are the result of the cutting of small pieces of sludge with a deviant color by the cutting edge of the cutting head. It is a typical wall-effect and is called smearing.
  - In case of a well cut sample the top section of the sample should be very watery (clear water). If this is not the case then, the next time you take a sample, you should pull the apparatus further up after feeling the bottom before you commence cutting. It is also possible to apply an electronic sludge layer detector to determine the transition between water and sludge.
  - Water on top of the piston has no significance. It leaked inside by passing alongside the piston rod.
- Now there is a selection between:
    1. Accessing the sample immediately and transferring it from the sampling tube to the wide-mouth sample flask afterwards.
    2. Transporting the sample in the sampling tube and examining it later.

To be able to execute procedure 1 the following is done:

- Examine or photograph the sample as it can be seen through the transparent sampling tube. If this method of visual examination is sufficient the apparatus can be placed in the wide-mouth flask and emptied. To maintain the anoxic character of the sample the flask will be filled to the rim. The rim should be cleaned properly in order to allow proper sealing.

Examine the sample after it has been removed from the sampling tube. This can be executed as follows:

- Place a half-round plastic gutter (art. no.: 990812) with a length of at least 1 meter, or a sheet of plastic on the ground.
- Hold the Multisampler almost horizontal and screw handle (10) on the piston rod (11). Empty the sampler by keeping the piston rod stationary while pulling the sampler. In this way a 'roll' is created in which the layer thickness are maintained.
- The circumference of the sample has been disturbed most due to the wall-effects. For this reason the sample should be examined by opening it using a spatula. This avoids incorrect interpretation.
- The less the binding of the sludge, the easier it falls apart.
- Sub-samples can be taken using a spatula or a spoon.

To be able to execute procedure 2 the following is done:

- Take a polyethylene cap and place this next to the cutting head on the ground.
- Slacken the steel wire and remove the cutting head.
- Immediately press the cap firmly in the lower section of the transparent tube. If necessary the sample can be pulled up slightly by means of the piston rod.
- Unscrew the piston rod from the piston and remove the rod.
- Remove the top section from the sampling tube.
- Transport the sampling tube with the sample in a (semi)vertical position (not horizontal). This avoids mixing.
- A new sample can be taken after mounting another tube and piston.

### 3.3 Taking liquid samples

Principle of operation:

1. Column sampling:

The apparatus is pressed into the fluid. In order to maintain the layered character of the liquids the piston is kept at a stationary position in relation to the fluid. The stainless steel ball valve in the bottom section prevents loss of the sample taken.

2. Spot sampling:

The apparatus is lowered to the proper depth. By pulling up the piston completely the apparatus is filled with liquid from that particular depth (for instance the bottom of a reservoir).

3. Mix-sampling:

As under 2, but now the piston is raised a little (for instance 10 centimeters = 125 ml) at every sampling spot. In this way a mix-sample of ten spots, divided over the depth or over the surface, can be obtained in one action.

Application:

Assemble the Multisampler, fitted with an open cutting head. See to it that the wire is not pulled too tight. The hook that pulls the wires can be unscrewed or screwed in. Mount no more than two extension rods and the top piece and fit the piston rod with a cord (you could use a plasticized cord).

- Lower the apparatus until the right depth is reached (in case of application at greater depths the extension rods are mounted during the lowering of the apparatus).

If a column sample has to be taken:

- Then the piston is blocked at a stationary level, for instance by pulling the cord tight and by standing on it.
- Next the sampler is pushed down until it is filled-up completely or you reach the bottom of the reservoir.
- After this the apparatus is pulled-up.

In case a spot- or mix-sample has to be taken, action is taken as previously described. However, now the apparatus is kept stationary and the piston is pulled up.

- Disconnect all rods (you may disconnect the piston cord).

Mind the following:

- Fluid on top of the piston has no significance. It leaked inside by passing alongside the piston rod.
- In case of a well cut sample, the layer thickness has remained intact despite passing the ball valve. It is therefore possible to measure layer thickness.
- If a sample is taken from very heterogeneous material (for instance watery sand) a certain separation or de-mixing will take place. The entrance resistance of the ball valve allows water easier access than sand. Once inside the tube, the sand will settle. The sequence of the layers remains more or less intact, the thickness of the layers however will be disturbed.

If separation is not allowed, it is better to use the open cutting head. You may prevent the sample from running out of the tube by fitting the tube with a cap just before pulling it from the water.

- Examine or photograph the sample as it can be seen through the transparent sampling tube. If this method of visual examination is sufficient the apparatus can be placed in a wide-mouth flask and emptied. Hold the Multisampler almost horizontal so that the ball comes out of the seat of the ball valve. The contents of the tube will run into the wide-mouth flask.

It is also possible to transport the fluid sample in the sampling tube. To this purpose you should remove the piston rod. Turn the Multisampler upside down. Disconnect the tension rope and remove the ball valve. The ball will remain inside the sampling tube; it cannot be removed. Mount the cutting head on the tube. The sample is now ready for transportation.