

L2CE

— **ELECTRO
HYDRAULIC
LOAD CELLS**

PRESSURE
& LOAD CELLS



ELECTRO-HYDRAULIC LOAD CELLS

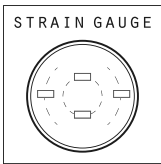

This model of load cells is used to monitor stresses in steel linings, struts, piles and support beams.

They consist of a pressure pad connected to a pressure transducer; the pressure pad is composed by two stiff stainless steel plates saturated by de-aired oil. Special distribution plates are also available for better load distribution between two not-parallel surfaces.

Electric cable connects the load cells to a suitable remote readout system.

APPLICATIONS

- steel lining in tunnel construction
- struts in big open excavation
- pile testing

FEATURES

- Specially designed for steel linings and struts
- Very robust construction
- Accurate and reliable
- Suitable for installation between not-parallel surfaces
- Remote data transmission with OMNIAlog datalogger

CE *Meet the essential requirements of the EMC Directive 2004/108/EC*

TECHNICAL SPECIFICATIONS

	MODEL 0L2CE019000	CE	MODEL 0L2CE030000	CE
Range	1900 KN		3000 KN	
OD	209 mm		264,5 mm	
Length (L)	365 mm		421 mm	
Overall size (ODxLxH)	209x365x36,5 mm		264,5x421x36,5 mm	
Accuracy (linearity, hysteresis and repeatability)	< 1% FS		< 1% FS	
Signal output	4-20 mA (current loop)		4-20 mA (current loop)	
Temperature operating range	from -20°C to +80°C		from -20°C to +80°C	
Protection Class	IP 68 up to 100 KPa		IP 68 up to 100 KPa	
Material	stainless steel		stainless steel	
Sensor resolution	15 kg		20 Kg	
Power supply	from 9 to 30 V DC		from 9 to 30 V DC	

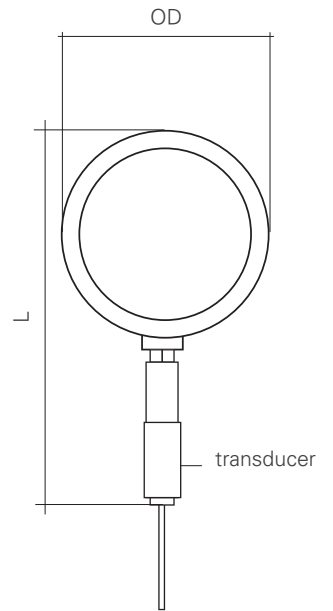

L2CE load cell with twin distribution plates

READABLE BY

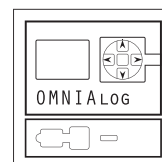
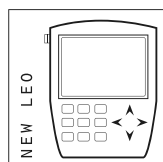
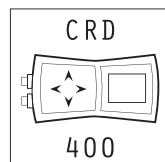

For further information refer to their own datasheets

DISTRIBUTION PLATES

In some application is very difficult that the two abutment plates where load cell shall be installed are perfectly parallel. In this case it is possible that the load will be distributed only over a part of load cell pad or, in the worst case, only on one point. This situation can generate a peak load that can damage the cell pad and moreover do not permit to the load cell to measure the real transmitted load. To solve the problem, Sisgeo can supply as option a kit of twin distribution plates, one with convex surface and one with concave surface.

This particular shape permits an equal load distribution over the load cell pad.

MODEL	DESCRIPTION	OD
0L2CE200PD0	Twin plates for 1.900 kN load cell	200 mm
0L2CE252PD0	Twin plates for 3.000 kN load cell	252 mm

TYPICAL TUNNEL INSTALLATION

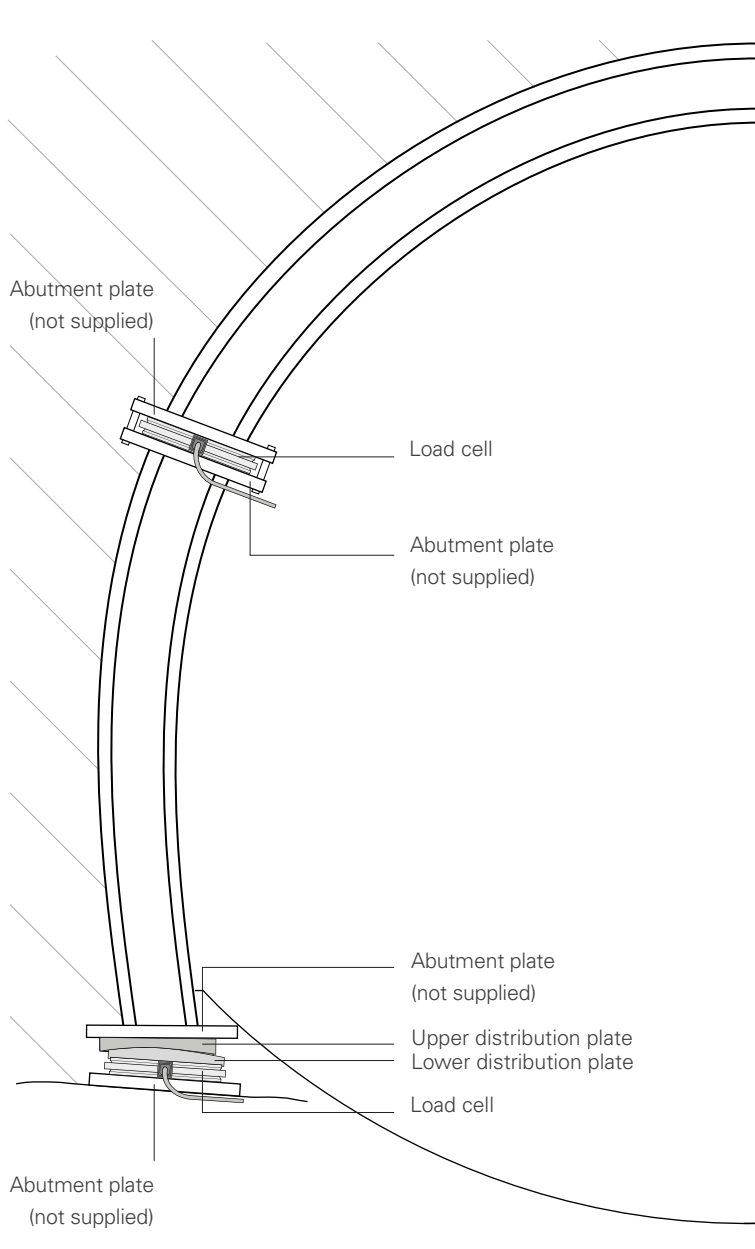

Load cell between two steel lining sections



Load cell under steel lining foot (distribution plates strongly suggested)

TYPICAL STRUT INSTALLATION

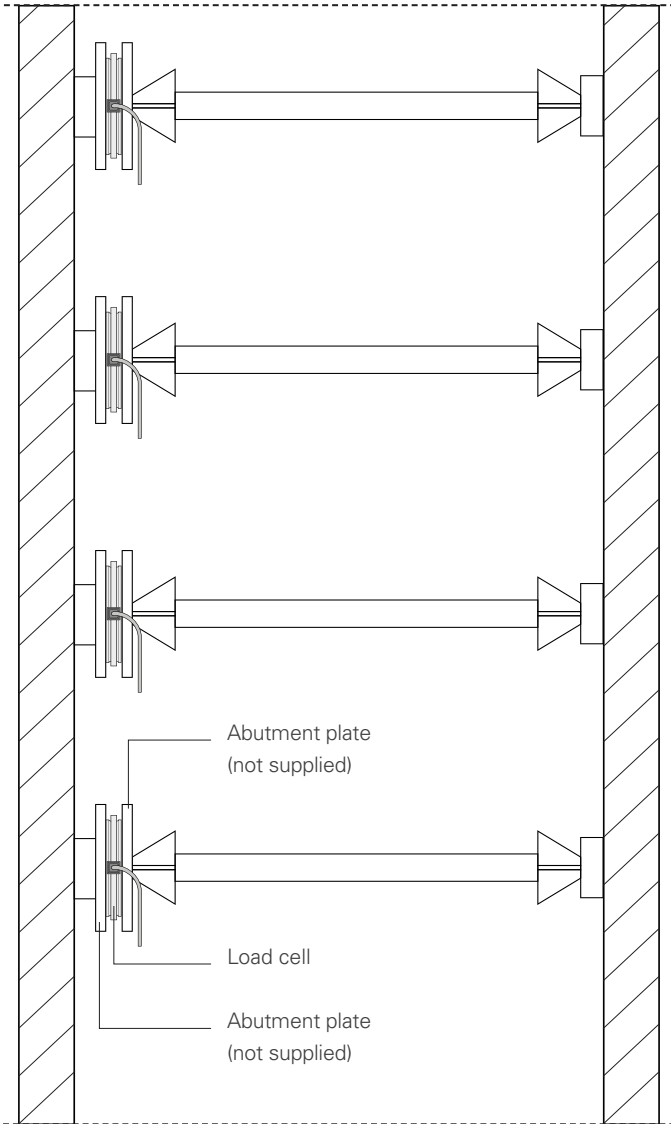

Struts in urban excavation for new Rome metro station

All the information in this document is the property of Sisgeo S.r.l. and should not be used without permission from Sisgeo S.r.l.
We reserve the right to change our product without prior notice.

SISGEO S.R.L.

VIA F. SERPERO 4/F1
20060 MASATE (MI) ITALY
PHONE +39 02 95764130
FAX +39 02 95762011
INFO@SISGEO.COM

ADDITIONAL SUPPORT

SISGEO offers on-line assistance service to the Customers in order to maximize the performance of the system and training on the correct use of the instrument/readout.

For more information contact mail: assistance@sisgeo.com