

#### Operating Principles

When the Solinst Double Valve Pump (DVP) is placed in a well or borehole, water rises inside the pump and the twin tubes to static level. A Control Unit is used to deliver compressed gas to the pump. During the drive period the gas pushes down on the water column contained in the drive line tubing, closing the check valve at the base of the pump. This forces water up the sample line tubing.

A vent period, during which the gas is released, allows hydrostatic pressure to refill the pump and drive line with sample water. The top check valve prevents water in the sample line from falling back into the pump body. This pressurization and vent cycle is repeated manually or automatically as set by the timers on the Control Unit. The cycle may be regulated for purging or sampling.

#### Pump Operation

**Portable:** The Pump will be attached to skip-bonded, dual 1/4" OD LDPE tubing, mounted on a reel.

- For the stainless steel model, push the tubing inserts into the end of the tubing and into the drive and sample compression fittings of the DVP (the nuts of the compression fittings may have to be loosened before inserting the tubing). Tighten the nut 1-1/4 turns past finger tight for proper seal (see overleaf).
- Lower the assembled DVP into the well, using a stainless steel safety line. The Solinst Model 103 Tag Line can be used for this purpose.
- Connect the supply line with the in-line dryer from the compressed gas source to the Control Unit. The drive line connects from the Control Unit to the reel.
- Attach a short (3 ft. or 1 m) length of 1/4" OD sample line to the sample connector on the reel.

**Dedicated:** The Pump will come with a roll of tubing to be cut to length, as required, for attachment to a Wellhead.

- Cut the tubing to desired length. See step a) above for tubing connection instructions to the stainless steel Pump.

For the PVC model, attach the 1/4" sample tubing to the compression fitting on the DVP and slide the 3/8" drive line tubing onto the barbed fitting and secure with the single ear Oetiker Clamp (see overleaf).

- Attach the sample and drive lines to the appropriate Push Fittings on the underside of the Wellhead.
- Lower the DVP into the well, using a stainless steel safety line if desired. If useful, attach the safety line to the suspension hook on the underside of the Wellhead. Push the Wellhead firmly onto the riser casing.
- Attach a short (3 ft. or 1 m) length of 1/4" OD sample line to the sample connector on the Wellhead. (See diagram at right for use of Push Fittings.)
- Connect the supply line with the in-line dryer from the compressed gas supply to the Control Unit. The drive line connects from the Control Unit to the top of the Wellhead.
- For detailed pumping instructions, please see the Solinst Model 466 Control Unit Operating Instructions.

- Notes:**
- The maximum lift for stainless steel (SS) pumps is 500 ft. (150 m), and 100 ft. (30 m) for the PVC model.
  - DO NOT** exceed an operating pressure of 250 psi for the SS model and 50 psi for the PVC model.
  - The pump has been decontaminated before leaving Solinst however, you may wish to decontaminate your pump before use. The pump should be decontaminated between wells.
  - Tube fittings are based on use of 3/8" drive line and 1/4" sample line. A 3/8" to 1/4" adaptor is also supplied, if dual 1/4" tubing is preferred.
  - Refer to the operating instructions in the lid of the Solinst Model 466 Control Unit for detailed pumping instructions.

#### Portable Sampling Setup

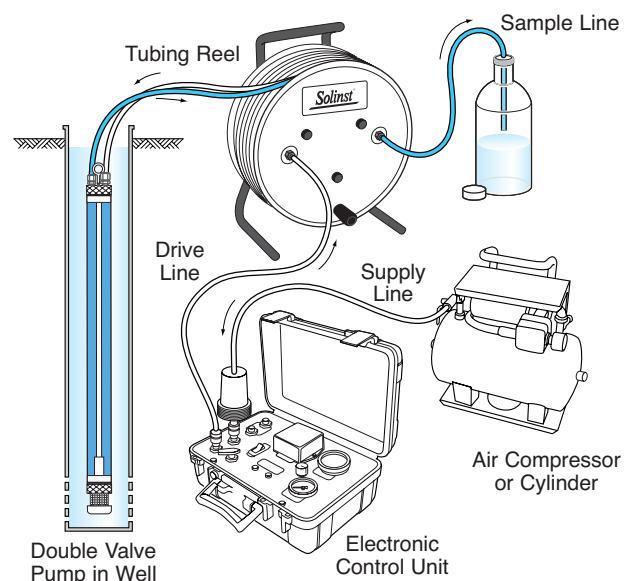

#### Dedicated Wellhead Setup

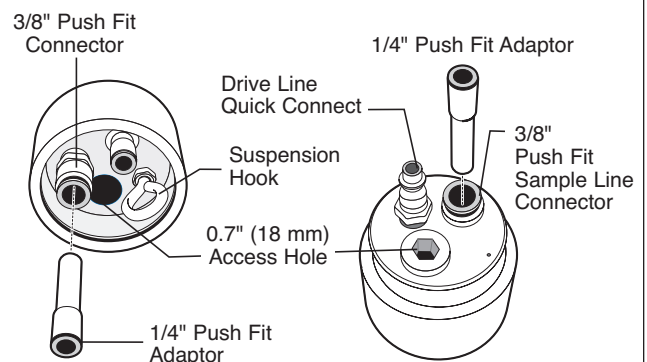

Wellheads come with two Push Fit Adaptors so that either 1/4" or 3/8" tubing can be used, as preferred.



To attach tubing just push into Push Fitting. To release tubing push down on both sides of the Top Ring and pull tubing out.

## Disassembly

1. Remove the Top Platen from the Pump Body and Riser. Remove the Pump Body from the Bottom Platen and slide it off the Riser.
2. Remove the Riser from the Valve Body, being careful not to lose the Check Ball.
3. Remove the Valve Body from the Bottom Platen, being sure not to lose the second Check Ball.
4. Remove the Filter Retainer from the Bottom Platen, and then remove the Filter Mesh from the Filter Retainer.

## Decontamination

- Notes:**
1. Always follow your local guidelines and standard protocols.
  2. Do not use acetone on the O-rings.

1. Completely disassemble the pump.
2. Wash all pump components with phosphate-free soap or a detergent.
3. Rinse all components thoroughly with deionized water and dry.
4. Replace worn O-rings as necessary, and then reassemble.

## Reassembly

1. Slide the Filter Mesh over the Filter Retainer until seated.
2. Thread the Bottom Platen onto the Filter Retainer until the O-ring is seated and the parts are finger tight.
3. Insert a Teflon® Check Ball into the top of the Bottom Platen.
4. Take the Valve Body and insert into the Bottom Platen until the O-ring firmly seats.
5. Insert a Teflon Check Ball into the top of the Valve Body.
6. Insert the bottom end of the Riser (hole downward) into the Valve Body.
7. Slide the Pump Body over the Riser and thread onto the Bottom Platen.
8. Take the Top Platen and while lining up the top of the Riser into the centre of the Top Platen, thread the Pump Body to the Top Platen.

**Note:** With PVC Pumps there is the option of using a stainless steel weight threaded into the Filter Retainer to reduce buoyancy during operation. An optional Weight and Filter Retainer Assembly ( part #105881) is available from Solinst.

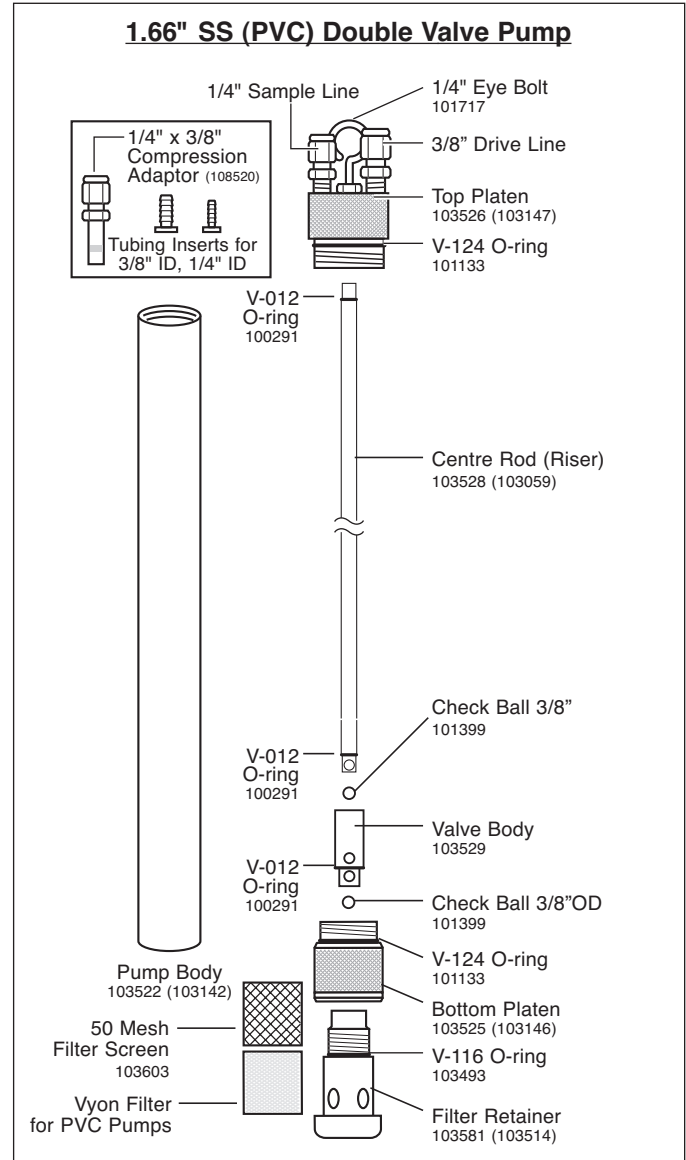

## Stainless Steel and PVC Tubing Connections

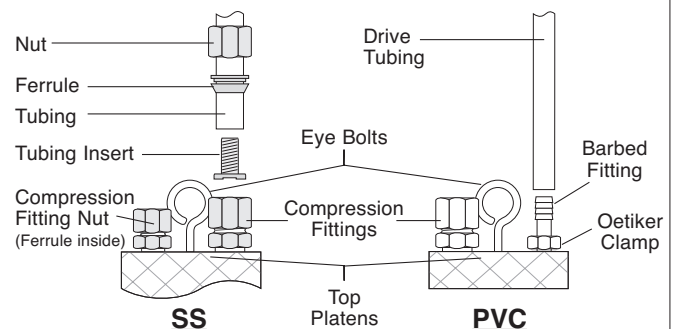

**Note:** Be careful not to lose the two pieces of the ferrule if loosening or removing the nut from the compression fitting.

® Teflon is a registered trademark of DuPont Corp.